



# CONFEDERAÇÃO BRASILEIRA DE AUTOMOBILISMO



## FICHA DE HOMOLOGAÇÃO

## FLANGE DO CARBURADOR

Fabricante	<i>Manufacturer</i>	IAME S.p.A
Marca	<i>Make</i>	IAME-PARILLA
Modelo	<i>Model</i>	Flange 22 mm
N° Homologação	<i>N° Homologation</i>	
Válida até	<i>Valid until</i>	3 ANOS + 1 DE CARÊNCIA
Número de páginas	<i>Number of pages</i>	02

Esta Ficha de Homologação reproduz descrições, ilustrações e dimensões do motor no momento da homologação pela CIK-FIA ou CNK-CBA. A altura do motor completo em todas as fotos deve ser, no mínimo, 7 cm.

*This Homologation Form reproduces descriptions, illustrations and dimensions of the engine at the time the CIK-FIA or CNK/CBA conducted the homologation. The height of the complete engine on all photographs must be as a minimum 7 cm.*



FOTO DA FLANGE LADO A  
PHOTO OF INLET CONVEYOR SIDE A



FOTO DA FLANGE LADO B  
PHOTO OF INLET CONVEYOR SIDE B



Assinatura e carimbo da CBA  
*Signature and stamp of the ASN*

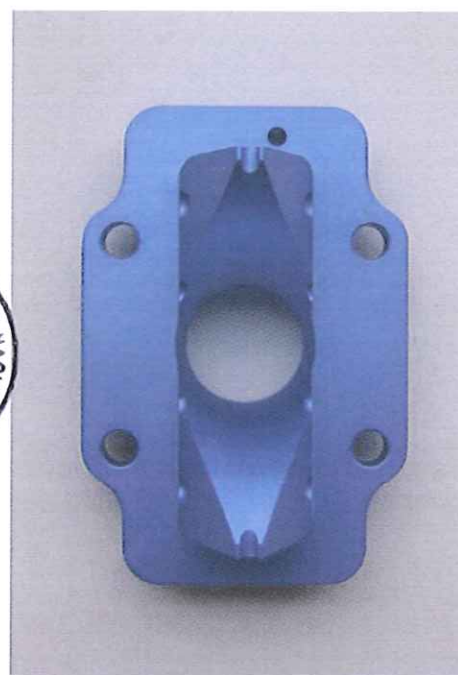

Assinatura e carimbo do fabricante/importador  
*Signature and stamp of the manufacturer/dealer*

IAME S.p.A.  
Administratore Delegato

MG Ind e Com S/A  
Diretor Presidente  
Gianfranco Ventre

DESENHO TÉCNICO DA FLANGE DO CARBURADOR  
DRAWING OF THE INLET CONVEYOR

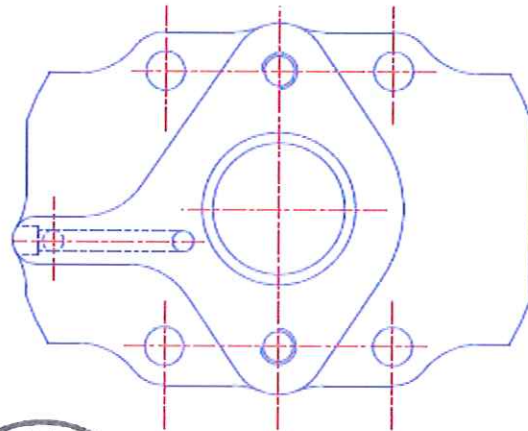
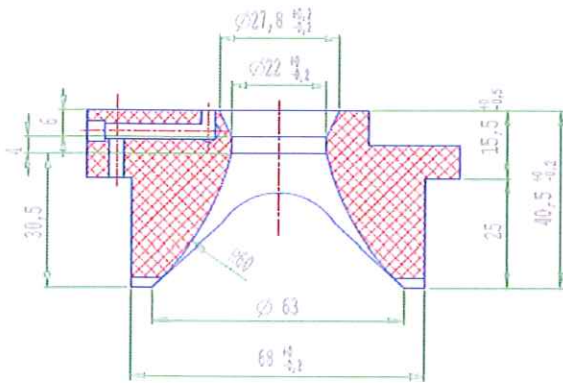

*[Handwritten signature]*