



## CARBURETTOR Tillotson HW-48A



PHOTO OF ADJUSTING SIDE



PHOTO OF INLET SIDE

Manufacturer	TILLOTSON LTD.
Make	TILLOTSON
Model	HW-48A

## SECTION VIEW

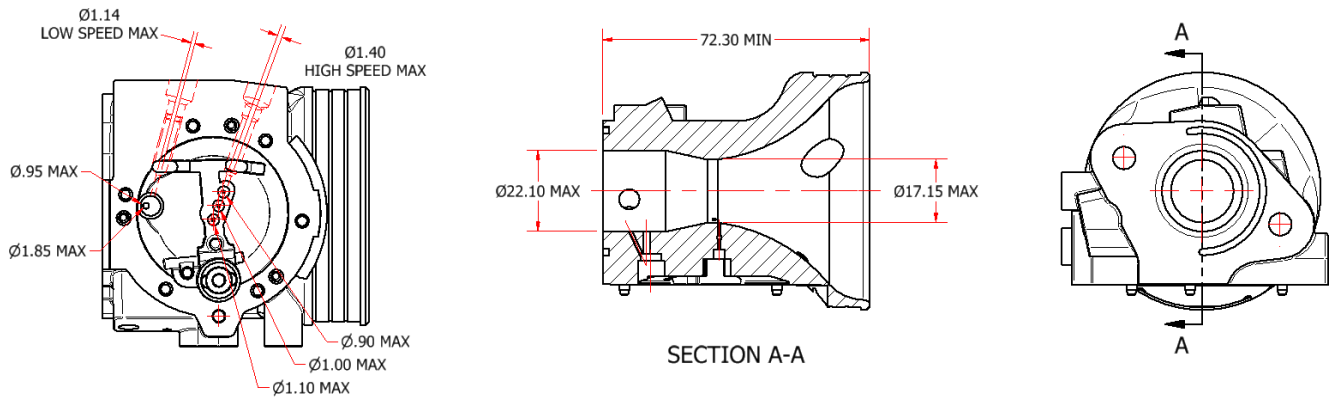

## MARKING



# CARBURETTOR DESCRIPTION AND SKETCH OF PARTS

HW-48A

ITEM	QTY	PART NUMBER	DESCRIPTION
1	1	219-D325	MACHINED BODY
2	1	16-B199	* COPPER GASKET, INLET SEAT
3	1	34-216	* INLET NEEDLE
4	1	155-A27	* INLET VALVE CONTROL LEVER
5	1	32-79	FULCRUM LEVER PIN
6	1	15-B329	FULCRUM LEVER SCREW
7	3	80-160	BRASS PLUG
8	1	179-62	** METERING GASKET
9	1	16-B217	** DIAPHRAGM ASSEMBLY
10	1	237-600	** PUMP GASKET
11	1	16-B392	** FUEL PUMP DIAPHRAGM
12	1	237-162	** FUEL PUMP BODY
13	1	141-89	* STRAINER GASKET
14	1	16-B205	FUEL STRAINER SCREEN
15	1	95-170	WHITE STRAINER COVER
16	1	91-A251	COVER SCREW
17	1	15-B313	ADJUSTMENT SCREW SPRING
18	2	24-B449	ADJUSTMENT SCREW SPRING
19	2	44-361	ADJUSTMENT SCREW O-RING
20	2	78-A256	ADJUSTMENT SCREW WASHER
21	1	29-224	THROTTLE SHAFT CLIP
22	1	15-C19	4-40 UNC SCREW
23	1	13-B215	THROTTLE SHAFT
24	1	14-A96	THROTTLE SHUTTER
25	1	15-C20	4-40 UNC SCREW
26	1	12-1218	THROTTLE LEVER ASSEMBLY
27	1	15-C52	LEVER SCREW
28	1	24-B381	THROTTLE RETURN SPRING
29	1	206-135	4MM BRASS BALL
30	1	62-A92	CARBURETTOR MOUNTING NUT
31	2	81-377	M4 X 0.7 SOCKET CAP SCREW
32	2	15-C67	METERING COVER ASSEMBLY
33	1	91-1031	INLET TENSION SPRING 26g
34	1	24-B323	* INLET SEAT
35	1	36-A27	CABLE BRACKET ASSEMBLY
36	1	136-559	6 - 32 UNC SCREW
37	6	15-C51	M4 X 0.5 ADJUSTMENT SCREW H
38	1	43-1045	8-32 UNC ADJUSTMENT SCREW L
39	1	43-1046	

PARTS LIST

ITEM QTY	PART NUMBER	DESCRIPTION
1	1	16-B199 * COPPER GASKET, INLET SEAT
2	1	34-216 * INLET NEEDLE
3	1	155-A27 * INLET VALVE CONTROL LEVER
4	1	16-B217 ** METERING GASKET
5	1	237-600 ** DIAPHRAGM ASSEMBLY
6	1	16-B392 ** PUMP GASKET
7	1	237-162 ** FUEL PUMP DIAPHRAGM
8	1	16-B205 ** STRAINER GASKET
9	1	36-A27 * INLET SEAT

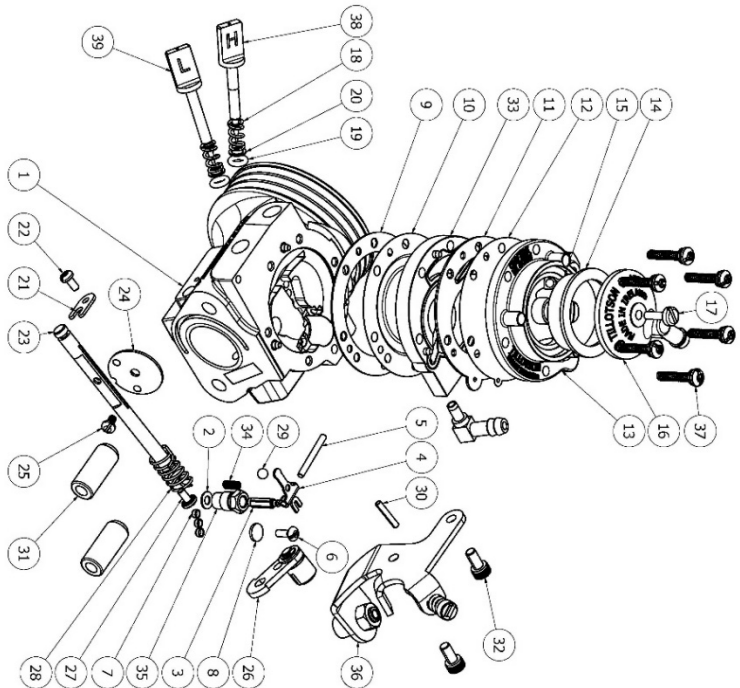
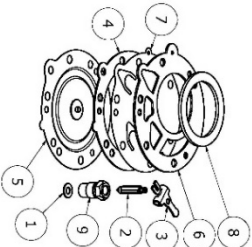

ITEM QTY	PART NUMBER	DESCRIPTION
1	1	16-B199 * COPPER GASKET, INLET SEAT
2	1	34-216 * INLET NEEDLE
3	1	36-A27 * INLET SEAT

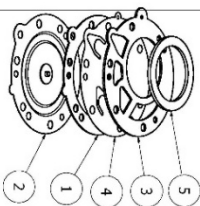
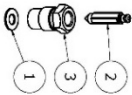

ITEM QTY	PART NUMBER	DESCRIPTION
1	1	16-B217 ** METERING GASKET
2	1	237-600 ** DIAPHRAGM ASSEMBLY
3	1	16-B392 ** PUMP GASKET
4	1	237-162 ** FUEL PUMP DIAPHRAGM
5	1	16-B205 ** STRAINER GASKET

PARTS OF CARBURETTOR

REF.9 - P. N°16-B217  
DIAPHRAGM GASKET



Thickness =  $0.5 \pm 0.1$  mm

PUMP DIAPHRAGM GASKET  
REF.11 - P. N° 16-B392



Thickness =  $0.8 \pm 0.1$  mm

REF.10 - P. N°237-600  
DIAPHRAGM

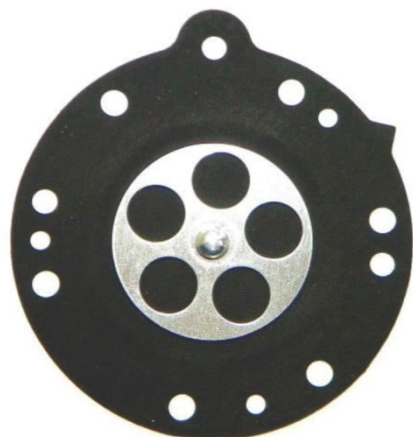

Thickness =  $0.13 \pm 0.07$  mm

REF.12 - P. N°237-162  
PUMP DIAPHRAGM



Thickness =  $0.10 \pm 0.063$  mm

**REF.33 - P. N° 91-1031  
DIAPHRAGM COVER**



Thickness =  $6.75 \pm 0.15$  mm

**REF.13 - P. N° 141-89  
PUMP COVER**



Thickness =  $12.5 \pm 0.15$  mm

**REF. 24 - P. N° 14-A96  
THROTTLE SHUTTER**

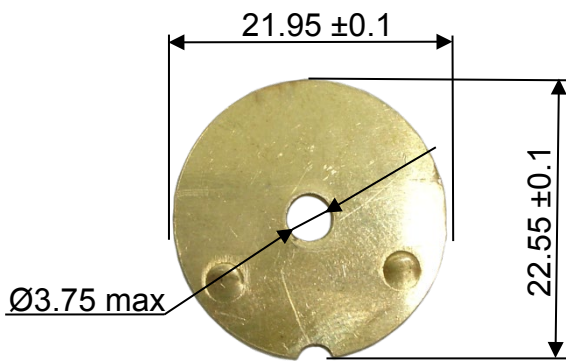

Thickness =  $0.81 \pm 0.1$  mm

**REF. 35, 3 - P. N° 233-720P  
SEAT + NEEDLE**

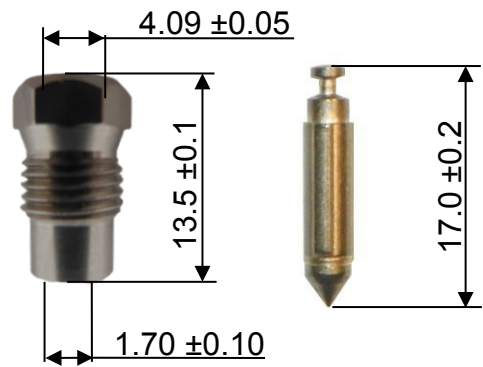

**REF.39 - P. N° 43-1046  
NEEDLE LOW SPEED**



**REF.38 - P. N° 43-1045  
NEEDLE HIGH SPEED**

